



COLEMAN SPA
PRE-DELIVERY GUIDE





www.colemanspas.com

Contents

Pre-Delivery Checklist	1
Planning the Best Location	1
Site Preparation	3
Getting the Spa Into Your Yard	4
Electrical Requirements	6
<i>Electrical Requirements – US and Canada</i>	6
240 Volt Electrical Installation	6
VS-500 System High Power Configuration.....	9
120 Volt Electrical Installation	10
Spa Technical Specifications	11

Copyright 2009-2010 LMS, Inc. All rights reserved. Duplication without written consent is strictly prohibited.

 ,  , and Coleman® are registered trademarks. Used under license. ©2010 The Coleman Company, Inc.

Due to continuous improvement programs, all models, operation, and/or specifications are subject to change without prior notice.

LTR50001094, Rev. A
4/19/10

CONTACT INFORMATION

For customer service, please contact your authorized dealer immediately. If you need additional information and/or assistance, please contact:

LMS Customer Service Department
1462 East Ninth Street
Pomona, CA 91766

Toll Free: 1-800-CAL-SPAS
Fax: 1-909-629-3890

www.colemanspas.com

Pre-Delivery Checklist

Most cities and counties require permits for exterior construction and electrical circuits. In addition, some communities have codes requiring residential barriers such as fencing and/or self-closing gates on property to prevent unsupervised access to the property by children under the age of 5. Your dealer can provide information on which permits may be required and how to obtain them prior to the delivery of your spa.

For additional operating and installation information, please see your selling dealer.

Before Delivery	
	Plan your delivery route
	Choose a suitable location for the spa
	Lay a 3" - 4" concrete slab
	Install dedicated electrical supply
After Delivery	
	Place spa on slab
	Connect electrical components

Planning the Best Location

Safety first

Do not place your spa within 10 feet (3 m) of overhead power lines.

Make sure the spa is positioned so that access to the equipment compartment and all side panels will not be blocked. Be certain that your installation will meet all city and local safety codes and requirements.

Consider how you will use your spa

How you intend to use your spa will help you determine where you should position it. For example, will you use your spa for recreational or therapeutic purposes? If your spa is mainly used for family recreation, be sure to leave plenty of room around it for activity. If you will use it for relaxation and therapy, you'll probably want to create a specific mood around it.

Plan for your environment

If you live in a region where it snows in the winter or rains frequently, place the spa near a house entry. By doing this, you will have a place to change clothes and not be uncomfortable.

Consider your privacy

In a cold-weather climate, bare trees won't provide much privacy. Think of your spa's surroundings during all seasons to determine your best privacy options. Consider the view of your neighbors as well when you plan the location of your spa.

Provide a view with your spa

Think about the direction you will be facing when sitting in your spa. Do you have a special landscaped area in your yard that you find enjoyable? Perhaps there is an area that catches a soothing breeze during the day or a lovely sunset in the evening.

Keep your spa clean

Prevent dirt and contaminants from being tracked into your spa by placing a foot mat at the spa's entrance where the bather's can clean their feet before entering your spa. You may also consider keeping a small water-filled basin nearby for bathers to rinse their feet before entering your spa.

In planning your spa's location, consider a location where the path to and from the house can be kept clean and free of debris.

Allow for service access

Many people choose to install a decorative structure around their spa. If you are installing your spa with any type of structure on the outside, such as a gazebo, remember to allow access for service. It is always best to design special installations so that the spa can still be accessed.

Site Preparation

Your spa needs a solid and level foundation. The area that it sits on must be able to support the weight of the spa, with water and the occupants who use it. If the foundation is inadequate, it may shift or settle after the spa is in place, causing stress that could DAMAGE YOUR SPA SHELL AND FINISH.

Damage caused by inadequate or improper foundation support is not covered by the warranty. It is the responsibility of the spa owner to provide a proper foundation for the spa.

Place the spa on an elevated 3" - 4" concrete slab. Pavers, gravel, brick, sand, timbers or dirt foundations are **not** adequate to support the spa.

We strongly recommended that a qualified, licensed contractor prepare the foundation for your spa.

If you are installing the spa indoors, pay close attention to the flooring beneath it. Choose flooring that will not be damaged or stained.

If you are installing your spa on an elevated wood deck or other structure, it is highly recommended that you consult a structural engineer or contractor to ensure the structure will support the weight of 150 pounds per square foot.

To properly identify the weight of your new spa when full, remember water weighs 8.33 lbs. per gallon. For example, an average 8' spa holds approximately 500 gallons of water. Using this formula, you will find that the weight of the water alone is 4,165 lbs. Combined with the dry weight of the spa you will note that this spa will weigh approximately 5,000 lbs. when full of water.

Your Coleman® Spas retailer can help you with your foundation and more. Your retailer has a wealth of information and experience about how to get the most out of your spa and can provide you with a full line of accessories that are designed to complement your spa and increase your enjoyment.

Getting the Spa Into Your Yard

Check the Dimensions of Your New Spa

The specification chart on page 11 lists your spa's model and its dimension as it sits on the delivery cart. During delivery, the spa must remain on the delivery cart at all times. Compare the dimensions to the width of the gates, sidewalks, and doorways along the delivery route. It may be necessary for you to remove a gate or partially remove a fence in order to provide an unobstructed passageway to the installation location.

Plan the Delivery Route

Consider the following when planning your delivery route:

- Check the width of gates, doors and sidewalks to make sure your spa will pass through unobstructed. You may have to remove a gate or part of a fence to allow for adequate width clearance.
- Are there low roof eaves, overhanging branches or rain gutters that could be an obstruction to overhead clearance?
- 8' spas need at least 42" wide gate and 9' height clearance.
- If the delivery route will require a 90° turn, check the measurements at the turn to ensure the spa will fit.
- Are there protruding gas meters, water meters or A/C units on your home which will cause obstructions along the delivery path to your yard?
- Are there stairs in your delivery route? If so, you must consult your Coleman® Spas dealer prior to delivery to make adequate preparations.

Special Circumstances

The use of a crane for delivery and installation may become necessary if you are unable to provide an adequate delivery route. It is used primarily to avoid injury to your spa, your property or to delivery personnel. Your Coleman® Spas dealer may be able to assist you with the arrangements. If your spa delivery requires the use of a crane, the cost of a crane is generally not included in the standard delivery service.

Check your width clearance

- Check all gates
- Protruding electric meters
- Gas meters
- A/C units

Do you have sufficient overhead clearance?

Check low roof eaves, overhanging branches, rain gutters

Is the path clear?

Move away branches, dog houses, firewood, etc.

If there is a 90° turn, can we clear it? (The spa will not bend.)

No stairs! If there are stairs in the delivery route, consult the dealer.

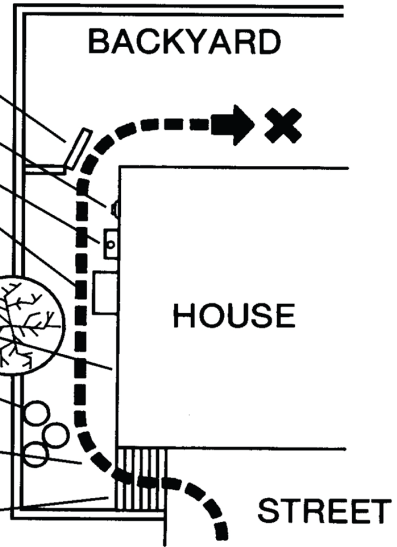

Electrical Requirements

Electrical Requirements – US and Canada

240 Volt Electrical Installation

All 240V spas must be permanently connected (hardwired) to the power supply. See the wiring diagram on page 8.

These instructions describe the only acceptable electrical wiring procedure. Spas wired in any other way will void your warranty and may result in serious injury.

When installed in the United States, the electrical wiring of this spa must meet the requirements of National Electric Code, ANSI/NFPA 70-2008 and any applicable local, state, and federal codes.

The electrical circuit must be installed by an electrical contractor and approved by a local building or electrical inspector.

Failure to comply with state and local codes may result in fire or personal injury and will be the sole responsibility of the spa owner.

GFCI and Wiring Requirements

The power supplied to the spa must be on a dedicated GFCI protected circuit as required by ANSI/NFPA 70 with no other appliances or lights sharing the power.

Use copper wire with THHN insulation. Do not use aluminum wire.

Use the table on the next page to determine your GFCI and wiring requirements.

When NEC requires the use of wires larger than #6 AWG, install a junction box near the spa and use #6 AWG wire between the junction box and the spa.

Wire runs over 85 feet must increase wire gauge to the next lower number. For example: A normal 50 amp GFCI with four #8 AWG Copper wires run over 85 feet would require you to go to four #6 AWG copper wires.

Read and follow the heater manufacturer's safety and installation instructions prior to installation and operation. Incorrect installation may damage the heater and void its warranty.

240V GFCI and Wiring Requirements

All VS-300 and VS500 control systems are set at the factory to run on the low power setting for low amperage operation. This is the default setting. Spa owners can have their installer change this setting so the spa will run on high power for 50 or 60 amp operation.

Warning: Never set a spa to run on high power without installing a properly rated GFCI.

Spa Model		GFCI Required	Wires Required
CO518R CO534L	VS-300 systems	One 40 amp GFCI	Four #8 AWG copper wires
CO756B CO756L	4050 control box -- VS-500 two pump systems Standard power mode	One 40 amp GFCI	Four #8 AWG copper wires
	4050 control box -- VS-500 two pump systems High power setting -- See configuration instructions below	One 50 amp GFCI	Four #8 AWG copper wires
CO866B CO866L CO866DL	4050 control box -- VS-500 three pump system Standard power mode	One 50 amp GFCI	Four #8 AWG copper wires
	4050 control box -- VS-500 three pump systems High power setting -- See configuration instructions below	One 60 amp GFCI	Four #8 AWG copper wires

GFCI Wiring Diagram

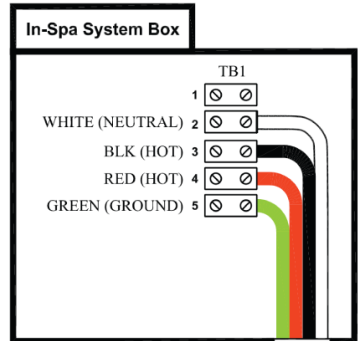
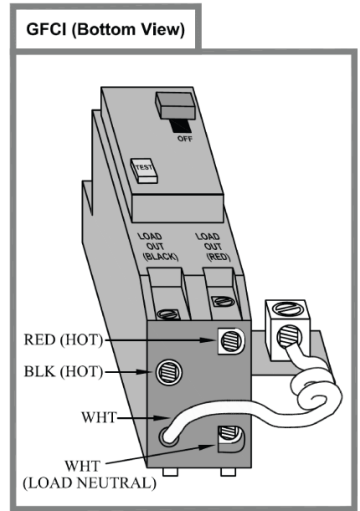
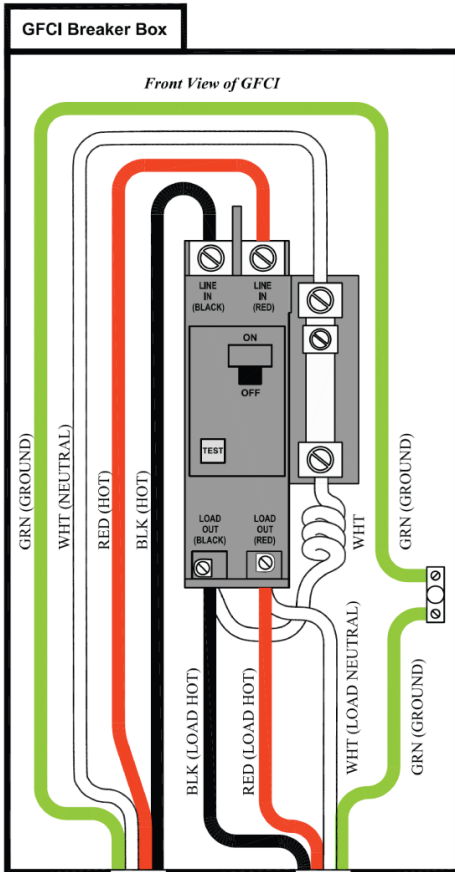
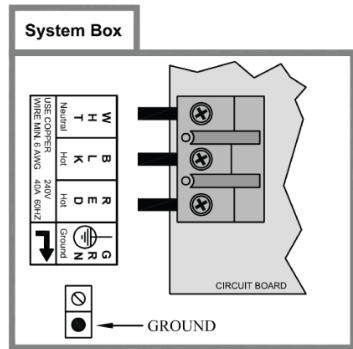
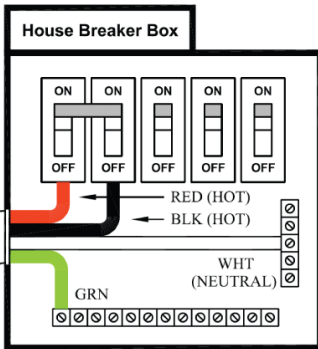

Testing the GFCI Breaker

Test the GFCI breaker prior to first use and periodically when the spa is powered. To test the GFCI breaker follow these instructions (spa should be operating):

1. Press the TEST button on the GFCI. The GFCI will trip and the spa will shut off.
2. Reset the GFCI breaker by switching the breaker to the full OFF position, wait a moment, then turn the breaker back on. The spa should have power again.

VS-500 System High Power Configuration

The two and three pump VS-500 systems can run with higher power than the VS-300 system. For the VS-500 system, DIP switch #6 is factory set in the ON position. This causes the heater to shut off when any pump is running in high speed. To operate the spa in high power mode, ensure the following steps are performed before starting your spa:

- When installing the electrical system, use a 50 or 60 amp GFCI as appropriate. (See the table above). Follow the GFCI wiring diagram on the previous page.
- Have your dealer or installer set DIP switch #6 to the OFF position on the circuit board as shown below.

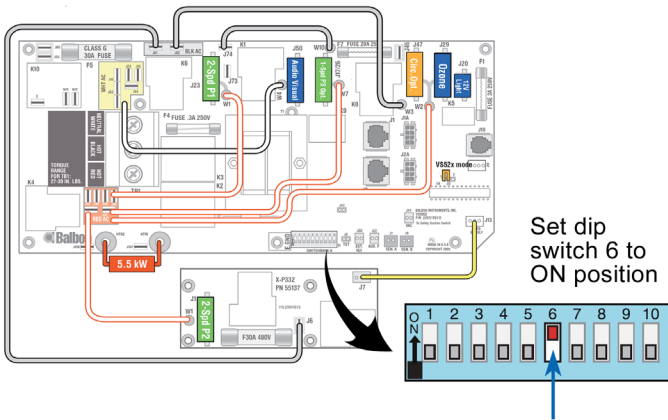

120 Volt Electrical Installation

Always follow applicable local, state and federal codes and guidelines.

Use only a dedicated electrical line with a 20-amp breaker.

Cord-and-plug connections may not use a cord longer than 15 ft (4.6 m) and must be plugged into a dedicated 20-amp GFCI connection. Do not use extension cords!

Always use a weatherproof-covered receptacle.

Receptacle shall be located not less than 5 ft (1.5 m) from and not exceeding 10 ft (3.0 m) from the inside wall of the spa.

Do not bury the power cord.

If your cord becomes damaged, replace it before next usage.

All 120V spas must have a GFCI. This can be either a 20-amp GFCI receptacle or a GFCI cord and plug kit as shown at right (CKIT110 - P/N ELE09700086).



Testing the GFCI Breaker

Test the GFCI plug prior to first use and periodically when the spa is powered. To test the GFCI plug version, follow these instructions. (Spa should already be plugged in and operational.)

1. Press the TEST button on the GFCI. The GFCI will trip and the spa will stop operating.
2. Press the RESET button on the GFCI. The GFCI will reset and the spa will turn back on.

The spa is now safe to use.

If the GFCI trips while the spa is in use, press the RESET button. If the GFCI does not reset, unplug the spa and call your local Coleman® Spas dealer for service. **DO NOT USE THE SPA!**

Spa Technical Specifications

All sizes on this chart represent outside dimensions. Due to our continuous improvements, specifications, size and pricing are subject to change without prior notice.

Model	Width	Length	Depth	Gallons	Dry Weight	Filled Weight
CO518R	78"	Round	35"	300	350 Lbs.	2850 Lbs.
CO534L	84"	64"	35"	352	600 Lbs.	3532 Lbs.
CO756B	84"	84"	35"	425	800 Lbs.	4340 Lbs.
CO756L	84"	84"	35"	425	800 Lbs.	4340 Lbs.
CO866B	93"	93"	35"	500	900 Lbs.	5065 Lbs.
CO866L	93"	93"	35"	500	900 Lbs.	5065 Lbs.
CO866DL	93"	93"	35"	500	900 Lbs.	5065 Lbs.



www.colemanspas.com